

Renewables Rendezvous 2010

Leveraging Gas Turbine Peaker Plants to Facilitate Development of Renewable Energy Projects



www.powereng.com



A question of opportunity

A stimulating question:
What is the grid interconnection part of a
renewable project worth?

Another question

How far would you walk for a free interconnect?

Peakers – An Entry for Renewables?

- Established permitted sites
- Established interconnections
 - Evaluated for full output
 - Evaluated for operation at any time
 - Anywhere from 50-400 MW in size
- Many located in areas of high summer load
- Many located in rural areas with developable land
- Operating hour limit typically air permit driven, not interconnect driven
- Some have unused space on-site

A Stealthy Interconnect?

- Peakers typically run only a small fraction of the year
- Their interconnection facilities are in place (and being paid for) 100% of the year.
- Each peaker unit has a transmission interconnection that has been studied, designed, permitted and built for continuous operation under peak load conditions
- This means that there is, in effect, a very large transmission backbone already installed with the capacity to deliver substantial number of new MWs with no additional transmission facilities being required

What are the Opportunities?

- Fill the “Gap”
 - Usually margin exists between transformer and generator ratings
 - May need to rely on forced cooling rating under peak load
- Replace lost summer capacity
 - Gas turbine output reduced during high temperature operation
 - Less of an opportunity with mechanically chilled plants
- Leverage Capacity Factor Differences
 - Peaker capacity factors typically 10% and can be less
 - PV capacity factor typically 15-20%
 - Wind capacity factor typically 25-40%

What Types of Renewables Fit Best?

- Wind and Solar PV
 - Can be built in small sizes
 - Can be expanded incrementally
 - Can be adapted to irregular real estate properties
- Solar Thermal
 - Typically at least 50 MW to be cost effective
 - Can add significant water use
 - Less accommodating of irregular real estate properties
 - Greater operator burden than PV or wind
 - Stirling might be an option though

Where are the Solar PV Resources?

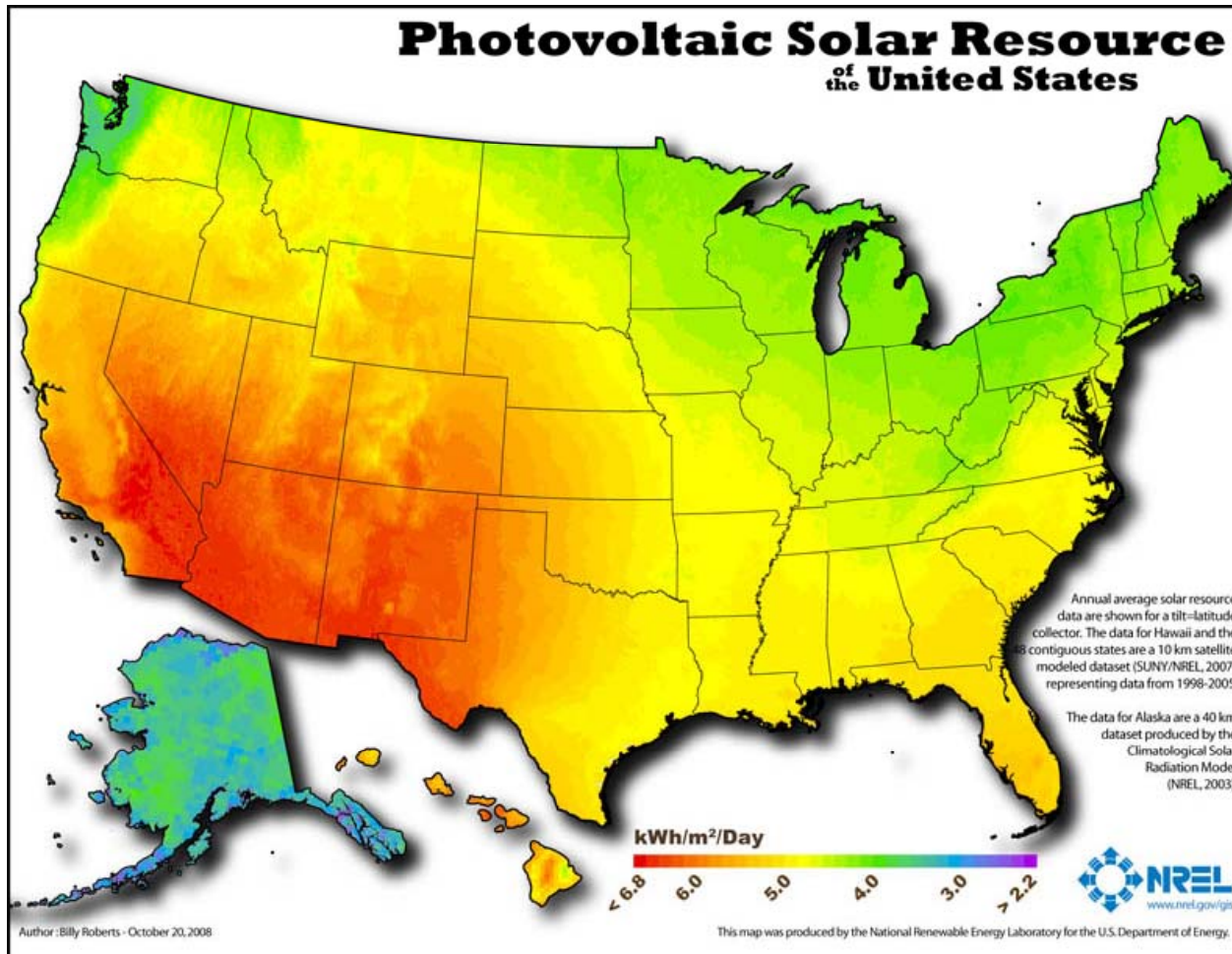

How about Solar Thermal Resources?

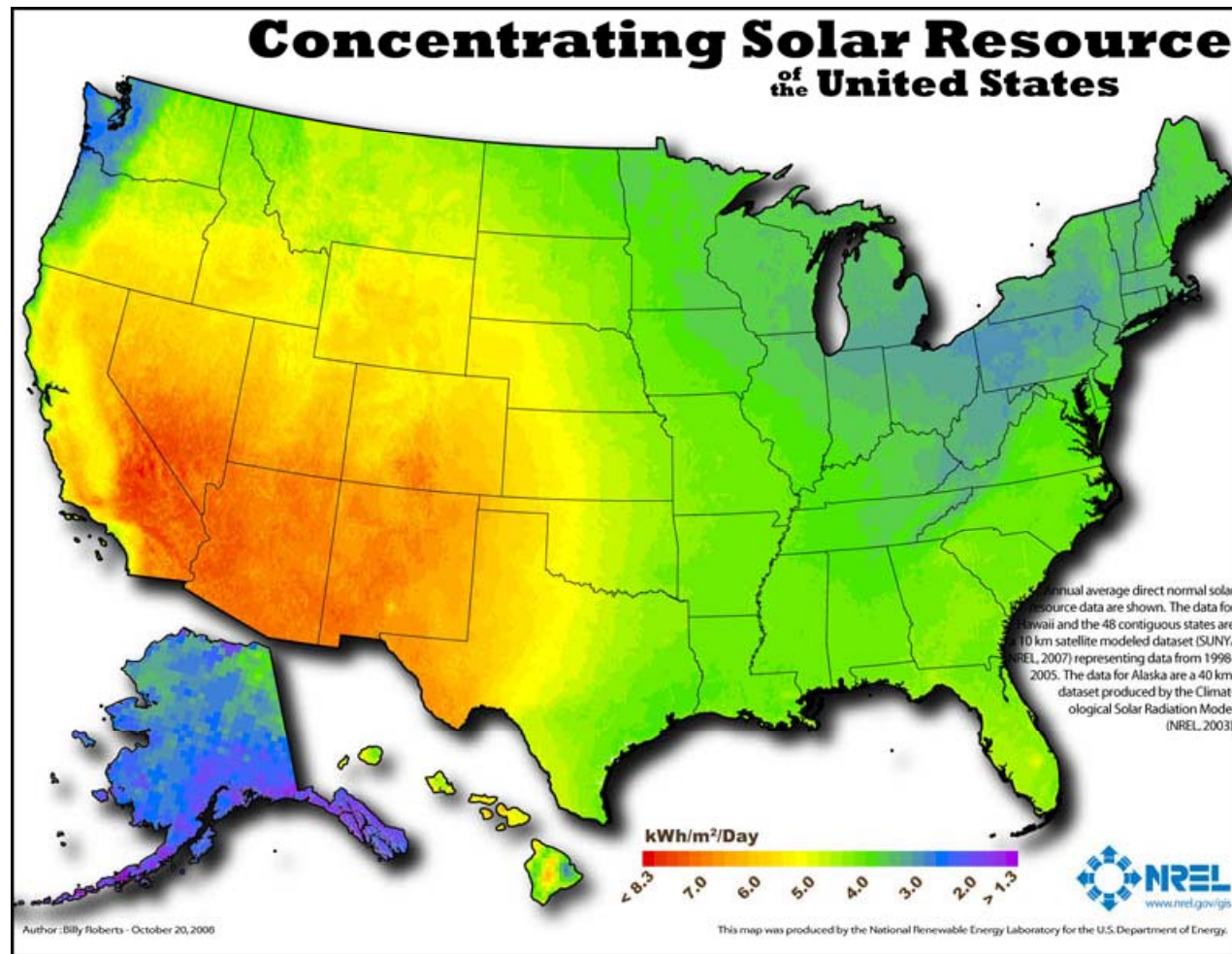

How about Wind Resources?

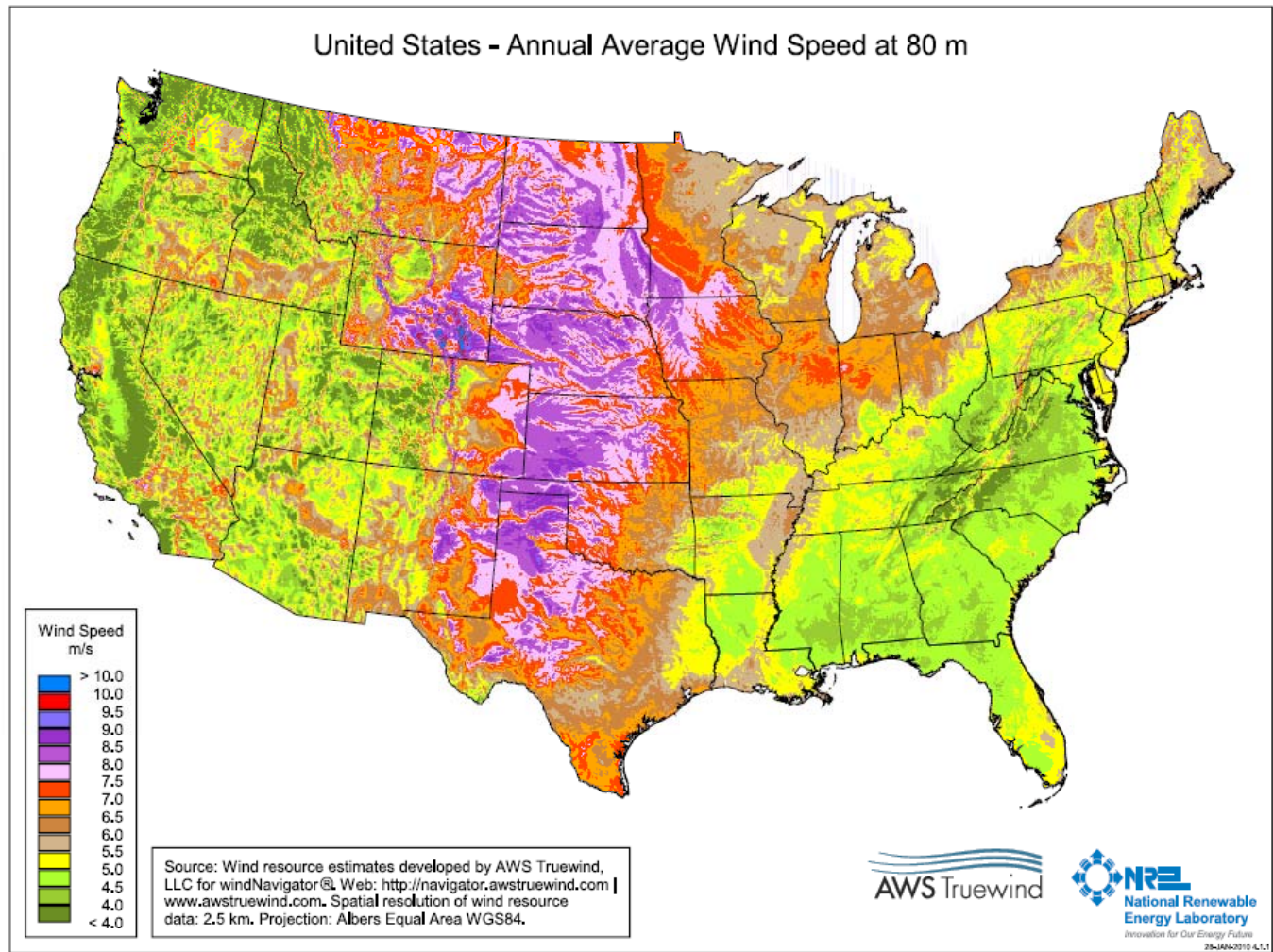

Legend of Generation Types

Mouse over symbols for more details.

	Major Electric Power Plants (>= 100 MW)	Renewable Energy Potential
Coal Mine, Surface	Coal	Biomass (>= 50 tons/sq km/yr)
Coal Mine, Underground	Geothermal	Geothermal (>= 80 milliwatts/m2)
Natural Gas Hub	Hydroelectric	Solar (>= 6.0 kWh/m2/day)
Petroleum Refinery	Natural Gas	Wind (>= 3 Power Class)
Oil Import Site	Nuclear	
Oil Seaport	Petroleum	
Electricity Transmission Line (>= 345 kV)	Solar	
Natural Gas Flow (1 mile band width = 100 million cubic feet/day)	Wind	
Oil and Gas Active Leases	Wood	
	Other Renewable	

Generation: California & Nevada

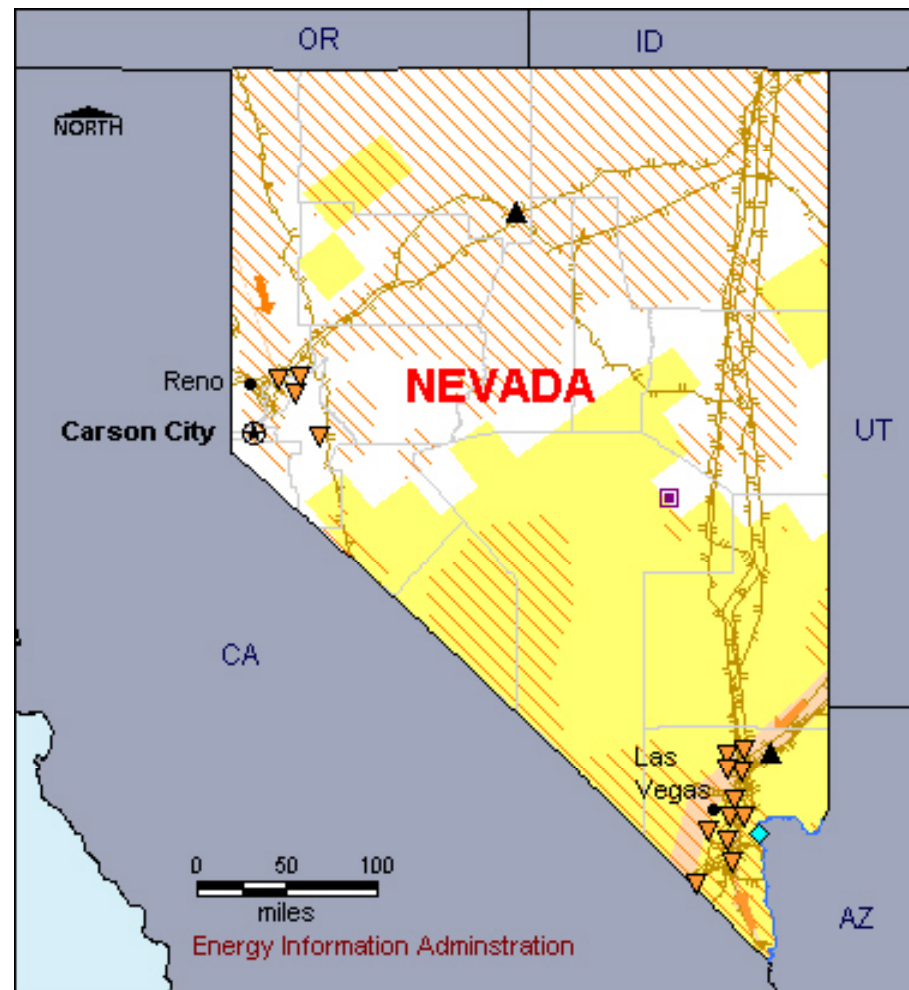
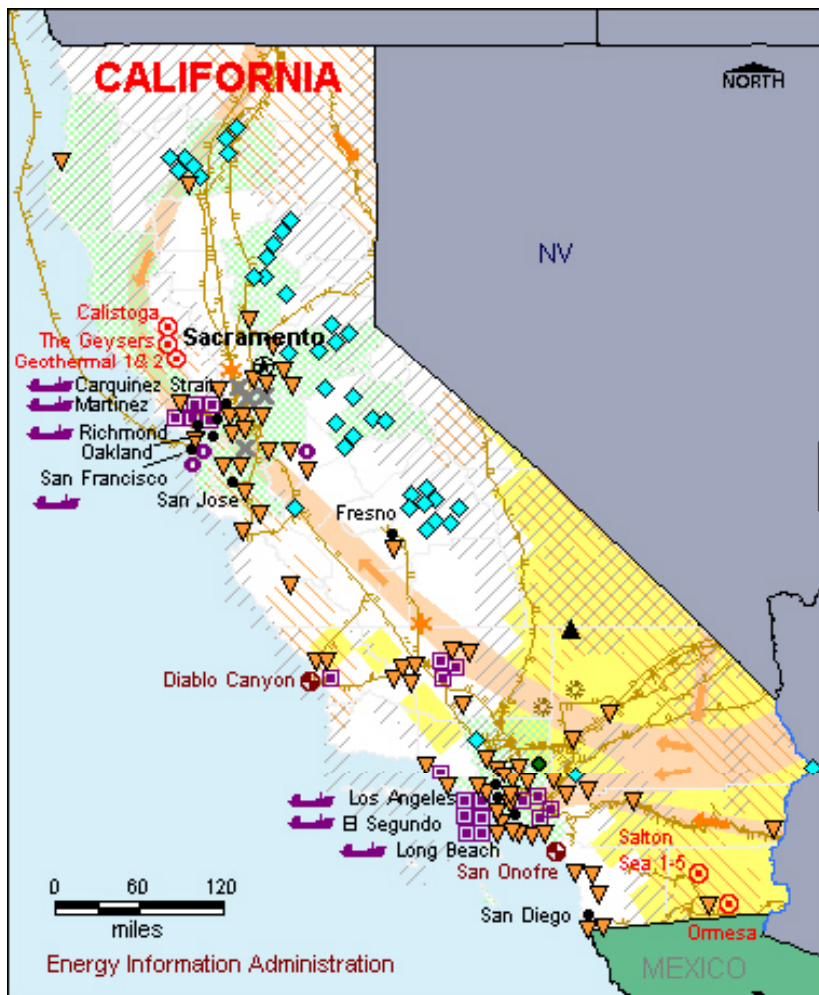

Generation: Arizona & New Mexico

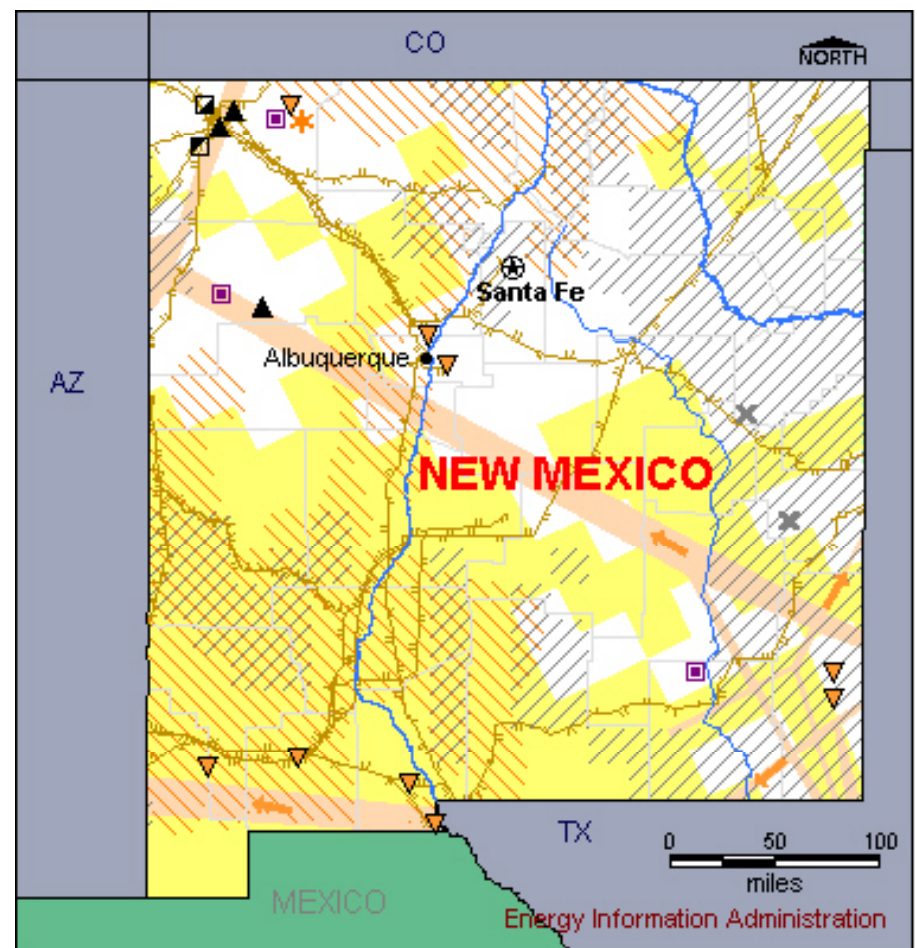

Generation: Texas

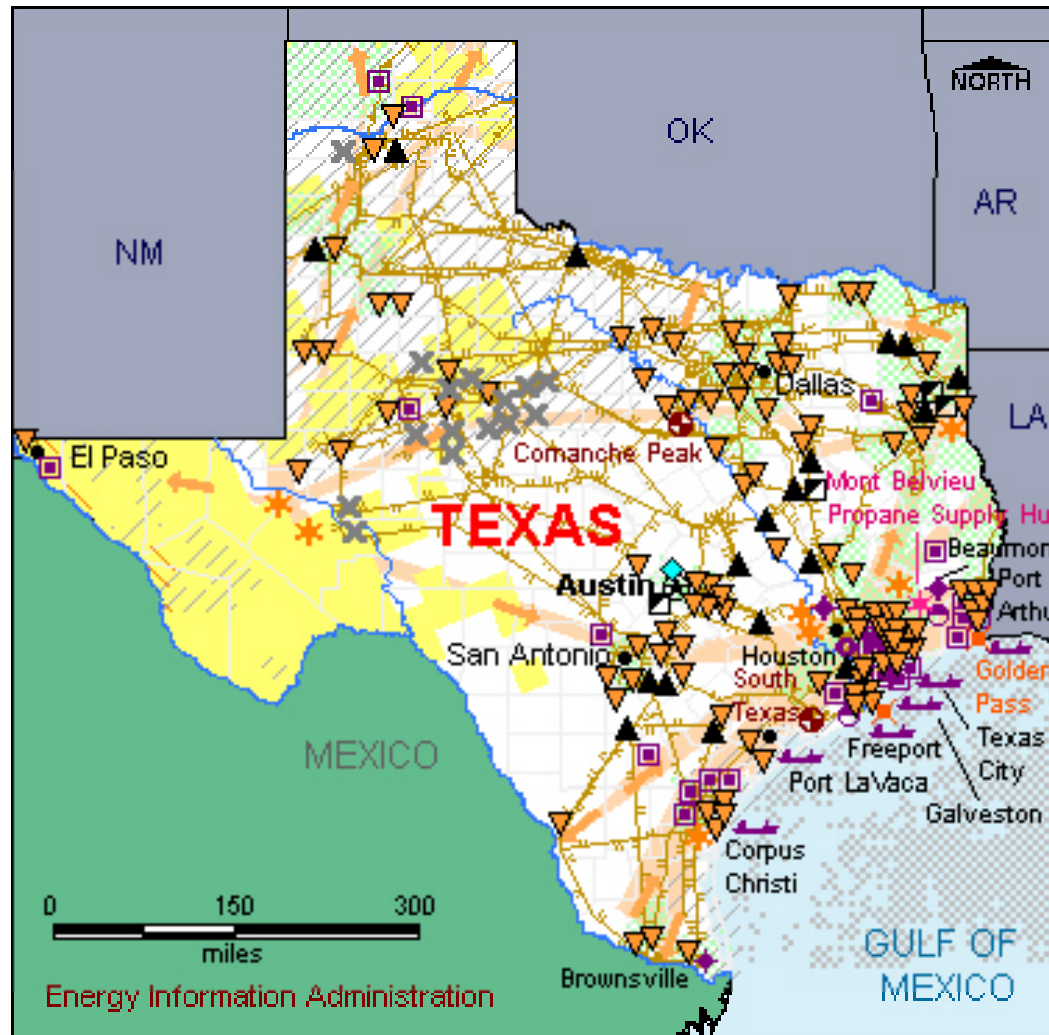

A Conceptual Example

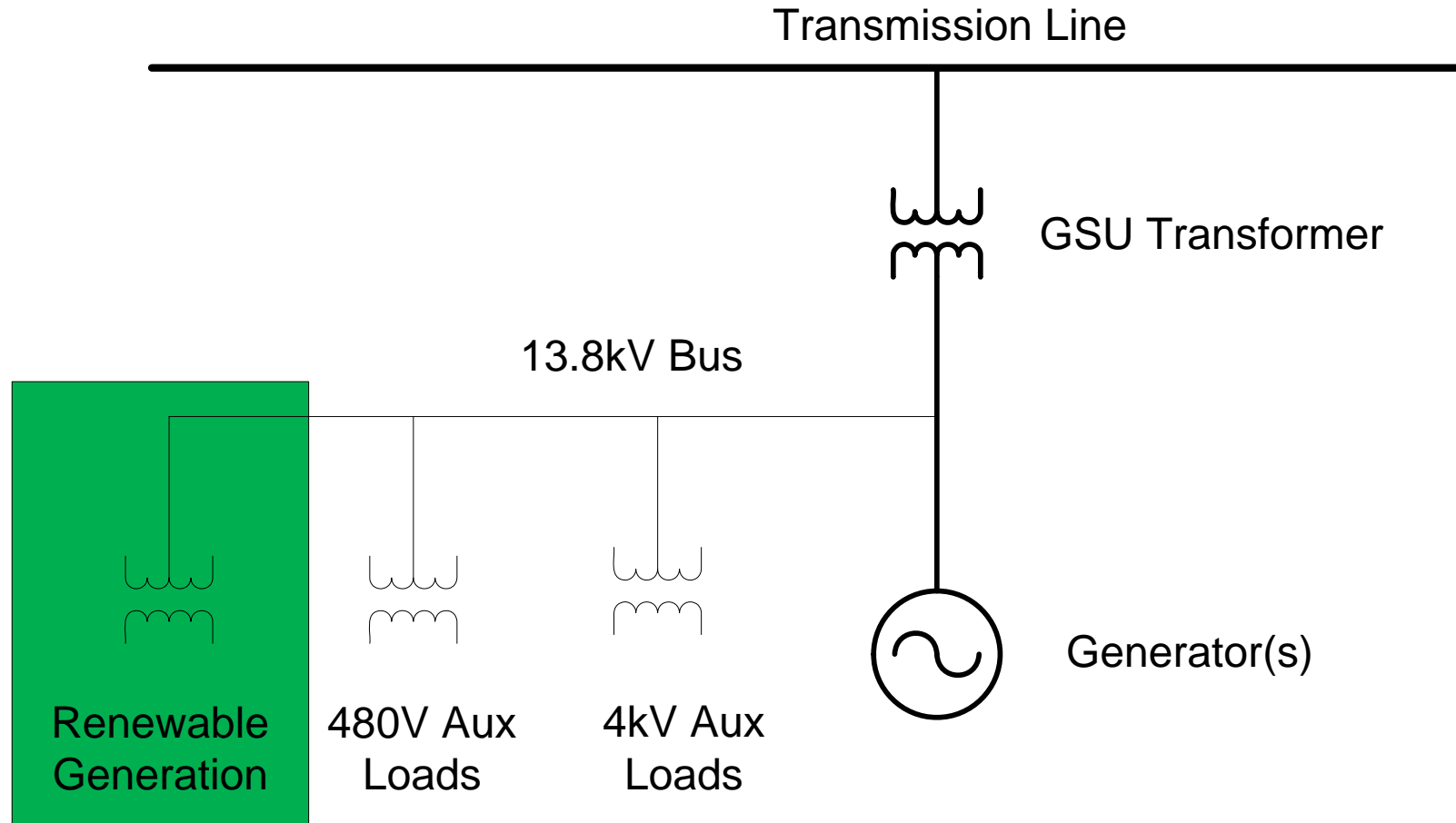

Some Additional Considerations

- Renewable resource availability
- Plant design considerations
 - Generator, transformer, bus, breaker ratings
 - How output varies over the day and year
 - May or may not be economically viable – it depends
- Conventional and renewable generation likely under separate PPAs – BUT transformer ties them together!
- New developments may want to allow for the other technology
- May have application to baseload generation too

Conclusions

Yes, Free Transformers! Existing peaking power plants may offer a readily available source of locations where the existing plant owner can easily and cost-effectively expand the peaking plant to incorporate an additional renewable energy component that utilizes the existing (and paid-for) interconnection.

