

Part 1: Two Approaches to Relay Integration

Low Cost Integration solutions for any Relay System

The single largest advantage of new microprocessor based relays is the reinvention of substation integration. Unlike traditional automation and SCADA systems that use transducers and RTU's to collect data, relays collect analog and digital data in addition to their primary protection tasks. This data can then be moved to a communications processor for distribution in a variety of ways according to a systems particular need. At this point, a utility has two choices: Local automation or System Wide automation. The key piece of equipment is the communication processor. The processor is installed and configured to collect data from the target relays, parse and concentrate the data needed by the automation system, and act as a protocol converter.

Part 1: Local Integration using Touch Panels

One of the easiest and most cost effective integration solutions available for substations are simple LCD touch panels. Touch panel solutions include:

- Display local meter, breaker position, and relay status information
- Control circuit breakers and enable/disable protection and control functions
- Offer an inexpensive, reliable alternative to PC-based solutions

System Overview

Figure 1 illustrates the key components of this system for a simple distribution substation. Data acquisition and breaker control are performed using microprocessor-based relays. An SEL-2030 Communications Processor, manufactured by Schweitzer Engineering Laboratories, Inc. of Pullman, WA, collects meter and status information from the relays and condenses that information into a smaller, relevant data set. An touch panel collects the data from the SEL-2030 using Modbus protocol, native to both devices.

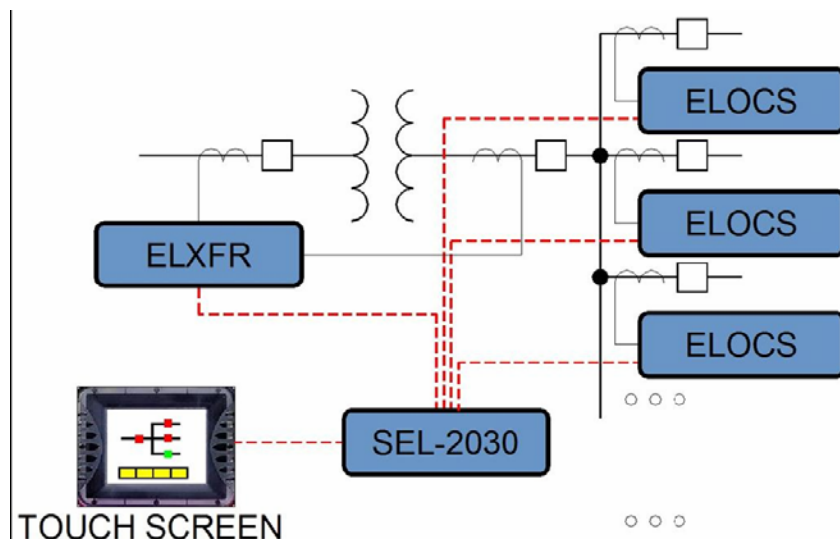

Figure 1: Substation Touch Panel System Overview

Touch Panel Capabilities

Real time substation information is displayed using a color touch panel. This touch panel can be mounted in the panel with an SEL-2030 or in a stand alone enclosure. The touch panel utilizes the Modbus protocol native in the SEL-2030. The touch panel—connected to a spare port on the SEL- 2030—can retrieve and display the data collected by SEL-2030 from the substation relays. The device has fully customizable screens to display as much information as desired. These customized screens are stored in Flash memory to eliminate accidental deletion caused by operator error or power outages.

A touch panel has many advantages:

- It is easy to use
- It is easy to program
- It has a long life expectancy
- It is a sealed unit
- It has no moving parts
- It is easy to update as the system changes
- It has a small physical size
- It communicates with the SEL-2030 using a native protocol.
- It is inexpensive compared with solutions based on substation PCs

Figures 2 & 3 show two example touch panel display screen captures developed for a project.

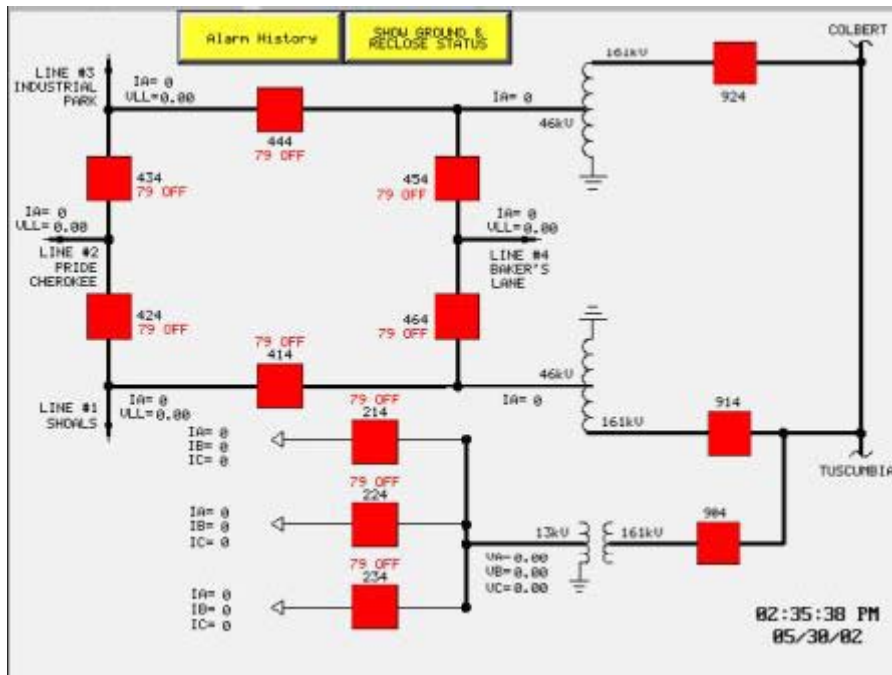

Figure 2: Example System Single Line

		67G		79		
RELAY		ENABLE	DISABLE	ENABLE	DISABLE	EXIT
LINE 1	311B	●	●	●	●	
	351A	●	●	⊗	⊗	
LINE 2	311B	●	●	●	●	
	351A	●	●	⊗	⊗	
LINE 3	311B	●	●	●	●	
	351A	●	●	⊗	⊗	
LINE 4	311B	●	●	●	●	
	351A	●	●	⊗	⊗	
LINE 214	351A	●	●	●	●	
LINE 224	351A	●	●	●	●	
LINE 234	351A	●	●	●	●	

Figure 3: Recloser and Ground Overcurrent Status Displayed on a Per Relay Basis

The touch panel can be configured to display meter quantities (Ia, Ib, Ic, Va), breaker position, and the status of several control inputs to the relays, used to indicate reclosing enabled/disabled and ground protection enabled/disabled (Figure 3). Additional meter and status indications are also possible, depending on the relays applied, including line or transformer real and reactive power measurements, system frequency, DC battery voltage, and trip coil monitor alarms.

In addition to the data display, it is possible to configure the touch panel for substation control functions as well, such as breaker trip and close. Relay control functions, such as setting group selection, reclose enable/disable, ground protection element enable/disable, and others are also possible, depending on the capabilities of the relays themselves.