

## Auto Transfer Scheme

In a previous article, we discussed using an automatic paging solution to improve distribution metrics (see article [here](#)). In this article, we discuss a way to protect customers from prolonged distribution outages while maintaining selective protection on your distribution system.

Recently, we designed an automatic source transfer scheme using two recloser controls. The scheme performs two main functions. First, upon losing a normal source, it auto transfers to an energized standby source. Second, it maintains the service to load for faults on the distribution system while both reclosers are operating in the closed position.

### Overview

Figure 1 demonstrates a distribution system with two load types, each using an auto-transfer scheme. Each load center is protected by two SEL-651R-equipped reclosers. SEL's proprietary Mirrored Bits protocol allows the relays to share digital status information securely and at a speed that allows the information to be used for protection purposes. Mirrored Bits protocol can be transmitted over a variety of communication channels allowing great flexibility in physical implementation. For a single point load, such as a substation, relays within 20 feet of each other can be connected using a copper serial cable. On the other extreme, a rural distributed load may place the reclosers 20 miles apart. Spread spectrum radios provide an easy and economical solution for distances up to 30 miles. Fiber optic channels can be implemented over even greater distances. Once the channel is set up, the protocol flexibility allows you to make scheme modifications without making wiring changes.

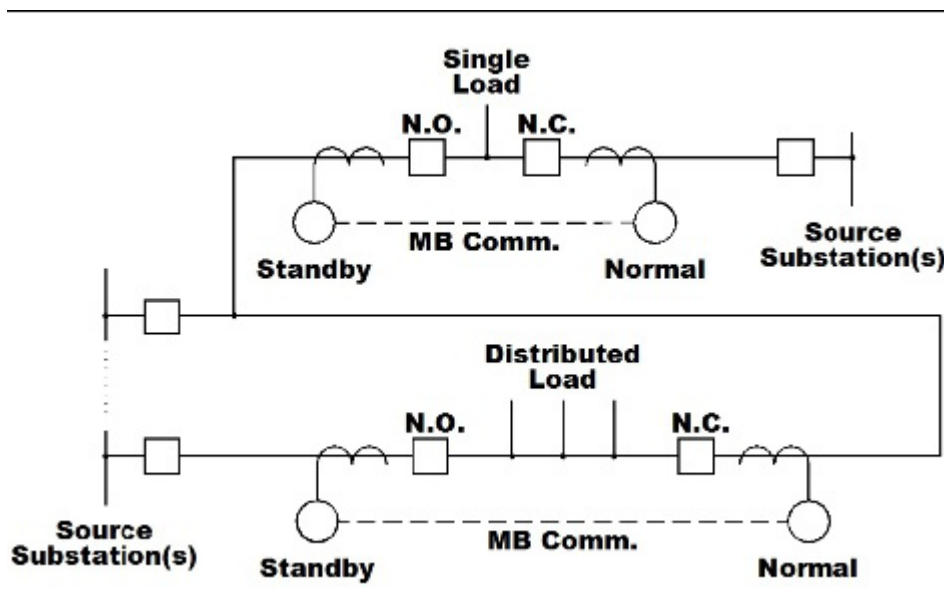

Figure 1

In this scheme, one recloser is normally closed (N.C.) and provides the normal source. The other recloser is normally open (N.O.) and provides the standby source. The scheme allows either recloser to be selected as the normal recloser. The opposite recloser is automatically designated the standby recloser. On occasion, both reclosers are closed in order to reconfigure the distribution system for maintenance or other outages.

Basic distribution overcurrent protection is coordinated between the SEL-651R's at the load and the source substation. To maintain proper coordination for all configurations, both SEL-651R's have identical overcurrent protection. When both reclosers are closed and a fault occurs beyond the load, only the recloser closest to the fault trips, thus maintaining service to the load.

When the normal source is lost during normal operation, the scheme transfers to the standby source. Once the normal source has been restored, the scheme automatically restores back to the normal configuration.

### **Directional Overcurrent Selection, Both Reclosers Closed**

Occasionally, both reclosers operate in the closed position. Tripping only the recloser closest to the fault maintains service to the load for downstream distribution faults. Monitoring recloser position and fault direction enables the relays to do this securely.

When both breakers are closed:

- The recloser detecting the reverse fault is always closest to fault, so is allowed to trip.
- If one recloser detects a forward fault and the other recloser does not detect a reverse fault, the fault is on the load bus. The recloser sensing the fault is allowed to trip.

### **Auto Transfer Scheme**

Using a push button, the user selects which recloser is the normal source and which is the standby source. Selecting the source type at one recloser control automatically selects the source type at the opposite recloser. A separate push button enables/disables the auto transfer scheme.

When the normal source is lost during normal operation, the scheme automatically transfers to the standby source.

A lost normal source is designated by the following:

- Normal recloser is closed
- Phase to ground voltage dips below 1.5 kV
- No fault current

Before the scheme begins the automatic transfer, it checks to ensure:

- The relays are communicating properly
- The auto transfer scheme is enabled
- The standby recloser is currently open
- A healthy voltage exists at the standby recloser

When these conditions are met for 30 cycles, the normal recloser simultaneously trips and sends the auto transfer signal to the standby recloser. The standby recloser waits 10 cycles to close. This allows the normal recloser to completely open, ensuring an open transfer.

When the normal source is healthy again, the scheme automatically restores to the normal configuration by closing the normal recloser, then opening the standby recloser. Before performing the automatic restore operation, the relay verifies the following conditions exist for five consecutive minutes:

- The auto transfer scheme is enabled
- The relays are communicating properly
- The standby recloser is closed
- The normal recloser is open
- An auto transfer must have been the last operation
- There is healthy voltage at both the normal and standby reclosers

Note that if normal and standby sources are from different substations, the hot close operation can be sync-check supervised, if necessary, using the relays built-in sync-check functions.

After the normal recloser closes, the standby recloser verifies the following:

- The last time it closed was for an auto transfer
- The relays are still communicating
- The auto transfer scheme is still enabled
- The voltage at the normal recloser remains healthy
- The normal recloser remains closed

The standby recloser trips when these conditions exist for 10 cycles.

normal recloser closed and the standby recloser open. An auto transfer does not occur if the system has been manually switched so that the standby recloser is closed and the normal recloser is open. The automatic restore only operates when an auto transfer was the last operation. An automatic restore only operates by opening the standby recloser and closing the normal recloser.

## **Conclusion**

This application used two SEL-651R relays. It can also be applied using any combination of SEL relays that include push button controls and Mirrored Bits (SEL-351R, SEL-351S, SEL-451 and SEL-421). All of these relays afford many incremental benefits. They provide superior protection capabilities, advanced scheme functionality (such as this one) and act as the front end for an integration system. Many of these relays are also available as part of an EasiLinc Protection Module, drastically simplifying the control scheme deployment.