**Three Terminal
230kV System Protection and Restoration
at Calpine's Creed and Goose Haven Energy Centers
Suisun City, California**

Larry Henriksen
POWER Engineers, Inc.
Hailey, Idaho

Daren Phelps
Calpine Corporation
Folsom, California

Greg Rauch
Schweitzer Engineering Laboratories, Inc.
Pullman, Washington

Aaron Wilson
POWER Engineers, Inc.
Portland, Oregon

Presented at the
30th Annual Western Protective Relaying Conference
Spokane, Washington
October 2003

Abstract

Calpine Corporation, a major independent power producer, recently completed two geographically separated energy centers, Creed and Goose Haven, approximately sixty miles northeast of San Francisco, California. Each energy center is rated 45 MW and is powered by a simple-cycle natural gas-fired combustion turbine. Calpine built a three terminal 230kV transmission line to interconnect these two energy centers with a northern California based, investor owned electric utility.

Calpine selected a protection and restoration scheme that took advantage of modern protective relay and communications technology to minimize cost while maintaining a high level of system performance. Numerical line differential protective relays, remote input/output modules, single mode fiber optic communications, and numerical reclosing relays were combined in a design that eliminated the need for two 230kV circuit breakers and their associated equipment and structures. The restoration scheme automatically identifies and isolates faulted equipment and restores the line, thereby, allowing the remaining generation facilities to be restarted and synchronized with the grid.

This paper discusses the restoration and protection scheme, including lessons learned from the project.

Project Overview

Calpine Corporation, a leading independent power producer with a current portfolio of 22,400 MW of generation (including 3,900 MW in California), recently conducted a program to construct and place in operation 15 peaking units totaling 675 MW. This new generation was constructed on a fast track schedule to provide power to the California Department of Water Resources and was part of the State of California's plan to add generation resources to prevent future blackouts following those experienced during the summer of 2000. The Creed and Goose Haven plants were part of this program.

The Creed and Goose Haven plants are located near Suisun City and Fairfield, California. The two plants are roughly sixty miles northeast of San Francisco. The two sites are geographically separated, with approximately two miles of distance between them. The plants have a simple-cycle configuration with one GE LM6000 aero-derivative natural gas-fired combustion turbine rated at 45 MW in each plant. Each plant includes a 13.8kV generator circuit breaker and a 230kV motor operated disconnect switch (MOD) to isolate the plant from the 230kV line.

A single circuit, overhead, three terminal 230kV transmission line constructed using single wood pole structures connects these plants to the Bithell Lane Switchyard.

The Bithell Lane Switchyard was built in association with another plant (the Calpine Lambie Peaker project) at a location approximately two miles away from the Creed and Goose Haven plants. The switchyard is constructed using a breaker-and-a-half bus topology with ownership divided between Calpine and a major Northern California investor-owned utility. Each entity owns two terminals of the four terminal breaker-and-a-half switching station and a fence separates the two sides.

Refer to Figure 1 for a single line of the transmission system.

Communication between Creed, Goose Haven, and Bithell Lane is provided by an all dielectric self supporting (ADSS) fiber optic cable suspended from the transmission structures beneath the

transmission conductors. The cable contains either 48 or 96 1300 nm single mode optical fibers, depending upon location. This cable is also used for metering and other plant communications.

Line protection is provided by a dual primary line differential scheme using numerical relays. Backup relaying is provided by distance and overcurrent elements in the line differential relays. Automatic line restoration is provided for single phase and two phase line faults, with the plants either being isolated (for a fault in the GSU or plant) or energized through the GSU (non-faulted plant). The restoration scheme is implemented using numerical reclosing relays, remote input/output modules, and hardwired logic in addition to the primary protection relays. Status and alarm signals are provided to the plant control systems. Operators can control line restoration through the plant control system.

Transmission System Alternatives

A high level of transmission system reliability and performance is required to serve the Creed and Goose Haven Plants. At the same time, transmission system cost is also a significant consideration for this class of generation plants. In addition, the topology and design requirements for the 230kV switching station are driven by the interconnected electric utility company. The bottom line: Control costs while maintaining system performance and meeting utility company requirements.

The use of a separate transmission line to each plant was rejected as cost prohibitive. To do so would have involved expansion of the Bithell Lane Switching Station and the addition of over a mile of 230kV transmission line. The expansion of the Bithell Lane Switching Station would have involved at least one, and probably two, 230kV circuit breakers. Additional bus, switches, protective relaying, and other associated equipment, as well as, additional site development would also have been required. The modern line differential relays contemplated for use on this project were designed to protect three terminal lines and, therefore, supported the emerging three terminal line design approach.

The next opportunity identified for cost saving was the elimination of 230kV circuit breakers at Creed and Goose Haven.

The plants each include a 13.8kV generator circuit breaker (refer to Figure 1) that will operate for generator faults (isolating the faulted generator from the system). The 13.8kV generator circuit breaker will also operate for the 13.8kV bus, generator step-up transformer (GSU), or transmission line faults (isolating the faulted bus, GSU or transmission line from the generator). However, in the case of a GSU fault or fault on the 13.8kV bus itself, the 13.8kV generator circuit breaker cannot interrupt the fault current contribution from the 230kV system or provide isolation from the 230kV system. To address this issue, a 230kV breaker would normally be applied at each plant. The 230kV breaker would also allow separation of the faulted plant from the system while keeping the non-faulted plant on line. In this instance, given that these are peaking units that only operate a portion of the time, coupled with their ability to be brought on line relatively quickly, the need to separate the faulted plant from the line without interruption of the non-faulted plant is not so critical. Hence, the 230kV plant breakers were eliminated. The 230kV breakers at the Bithell Lane Switchyard are operated to separate the 230kV system from GSU and 13.8kV bus faults at either plant.

If the plants are operating and one unit experiences a fault, it is critical to return the non-faulted unit to service as quickly as possible. To assist in returning the non-faulted unit to service quickly, the protection and restoration scheme includes a 230kV motor operated disconnect

(MOD) at the plants, which will be opened to isolate the faulted plant while the line is de-energized. The 230kV breakers at Bithell Lane will then re-close, re-energizing the line and the non-faulted generator step-up transformer, which in turn provides auxiliary power to the non-faulted plant. At this point, station service power to the non-faulted plant is restored and it can be returned to service.

It is important to note that there is little or no difference in the effect of a line fault with this scheme compared to having 230kV circuit breakers at the plants.

Replacement of the two 230kV circuit breakers (one at each plant) and the associated structures, switches, and site improvements with MODs resulted in a cost saving of approximately \$250,000. However, a more complex protection, control, and communications scheme is required for this design. The remainder of this paper describes this scheme. Note that the only additional equipment required is four remote input/output modules, a few lockout relays and wiring devices, and associated wiring.

Figure 1 illustrates the transmission system arrangement that was selected. Key points of this arrangement are:

- 230kV breaker and a half scheme at the Bithell Lane Switching Station
- Three terminal single circuit 230kV transmission line
- Use of motor operated disconnects (MODs) in lieu of 230kV circuit breakers at Creed and Goose Haven Plants.

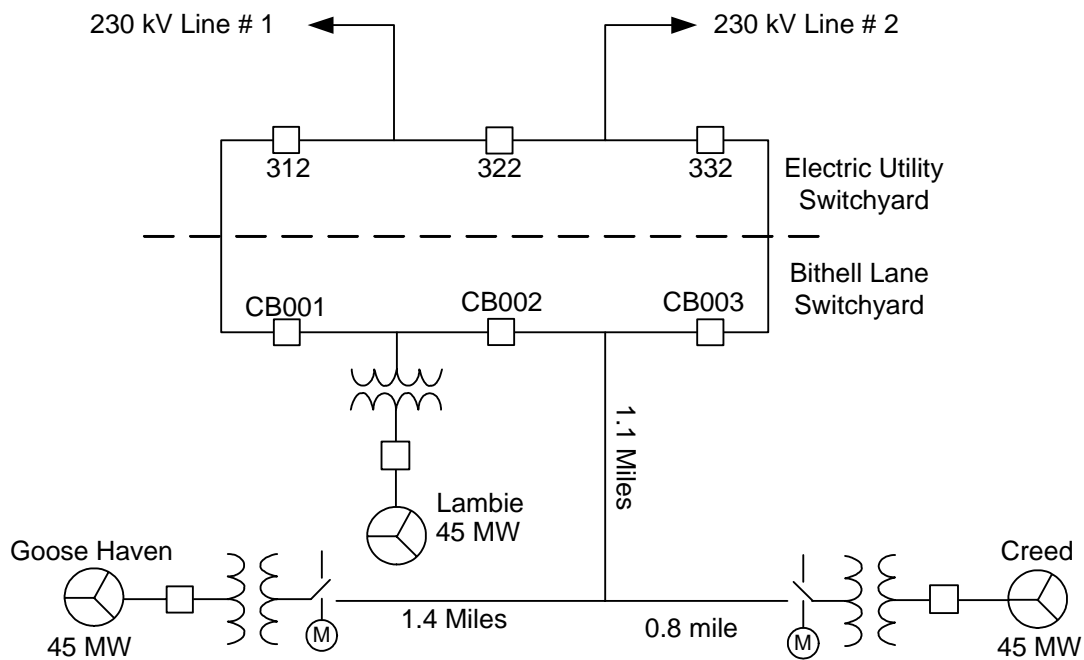

Figure 1. 230kV Single Line Diagram

Protection and Restoration System

System Requirements

The goals for the protection and restoration system performance are:

- Dependable, secure, and high speed tripping for line faults
- To the extent practical, backup protection for GSU and 13.8kV bus faults
- Auto-restoration for a limited class of line faults and plant faults
- Dependable line protection for single contingency component failures

Available Technology and Equipment Selection

The ready availability of capable and proven technology allowed a cost effective implementation of the protection and restoration scheme with off-the-shelf components.

Selection of protective relays was driven by the need to create a scheme to meet project requirements. Relay selection was also strongly influenced by the need to use electric utility approved devices. When possible, protective relays were selected from the utility's approved equipment list and if not possible, the selection was agreed upon with the utility's protection department.

Line Protection Relays:

- The present generation of multi-function numerical line differential relays provides a simple interface to fiber optic communications channels, minimizing equipment expense and labor. They provide a wide range of functions in addition to their principal function of line differential protection. These additional functions can include phase and ground distance elements, a full complement of directional and non-directional overcurrent elements, synch check, voltage elements, frequency elements, and general purpose logic.
- Two numerical line differential relay systems are used (a total of six relays), each with their own sets of current transformer (CTs) and separate, dedicated, optical fibers for communication. Relays from two manufacturers were used. Each is multi-functional and of the latest generation. They provide distance and overcurrent protection elements, as well as, general purpose logic capability.

Circuit Breaker Control:

- Numerical reclosing and breaker failure relays have long been available to provide breaker failure, reclosing, and synchronism checking. Their programmable logic can be used to customize relay functionality.
- A separate breaker failure relay from the utility's approved relay list is used.
- A two breaker numerical reclosing and synch check relay of older design is used in the restoration scheme as well as to provide controlled closing with synch check and live bus/dead line checking.

Contact Replication:

- Relatively inexpensive and easily applied remote input/output modules allow replication of contact closures across fiber optic communications channels with protection grade reliability and speed. They interface directly with optical fibers.
- Two sets of remote input/output modules are used to communicate circuit breaker and disconnect switch position indications and control functions. One set communicates between Creed and Bithell Lane and one between Goose Haven and Bithell Lane.

Communications Channels:

- Fiber optic communications has matured with a variety of cable designs to allow selection of an optical communication path that is cost effective and suited for the task, from both a mechanical and an optical perspective.
- All dielectric self supporting (ADSS) optical cable containing single mode 1300 nm optical fibers is attached to the transmission line structures below the conductors. Forty-eight fiber cables are used between the plants and the tee point of the line and 96 fiber cables between the tee point and Bithell Lane.

Hardwired Logic:

- Hardwired logic is used in conjunction with the numerical relay logic to implement the restoration. Control switches, selector switches, auxiliary switches and lockout relays are wired to provide interlocking and control logic.

Protection Overview

Refer to Figure 2 and Figure 3 for single line and block diagrams of the system.

Line current differential elements were chosen to provide primary line protection for the short (approximately two mile long), three-terminal line. The line differential protection relays easily accommodate both the three terminal configuration and the short line length while providing reliable, high speed operation. Total fault clearing time is expected to be four cycles, based on a one cycle relay response and a three cycle breaker time.

Backup line protection, in case of loss of the fiber optic cable or a device such as a junction box that results in loss of all fiber paths, is provided by a number of elements; implemented in both of the line differential relays at the Bithell Lane terminal:

- Time delayed phase mho distance elements
- Time delayed ground quadrilateral distance elements
- Phase instantaneous and inverse time overcurrent elements
- Directional ground instantaneous and inverse time overcurrent elements

Total fault clearing time for the backup distance protection is expected to be 17 cycles or less, based on a two cycle relay response, 12 cycle delay, and three cycle breaker time.

The plant constructor provided the protection for the Creed and Goose Haven plants. The interface between the line relaying and the plant protection was coordinated with the firm responsible for the plant design. Plant trip circuits and contacts from plant lockout switches are integrated into the protection and restoration scheme.

The multi-function line differential relays at Bithell Lane also provide a degree of backup protection for the plant through the same set of elements that provides backup line protection:

- Time delayed phase mho distance elements set to overreach the GSU and reach partway into the 13.8kV plant auxiliary transformer.
- Time delayed ground quadrilateral distance elements that set to overreach the GSU wye connected 230kV winding.
- Phase and ground overcurrent elements noted above.

The system is designed to continue to provide line protection with the failure of a single protection system element (communications link, a set of CTs, VT inputs, or a relay).

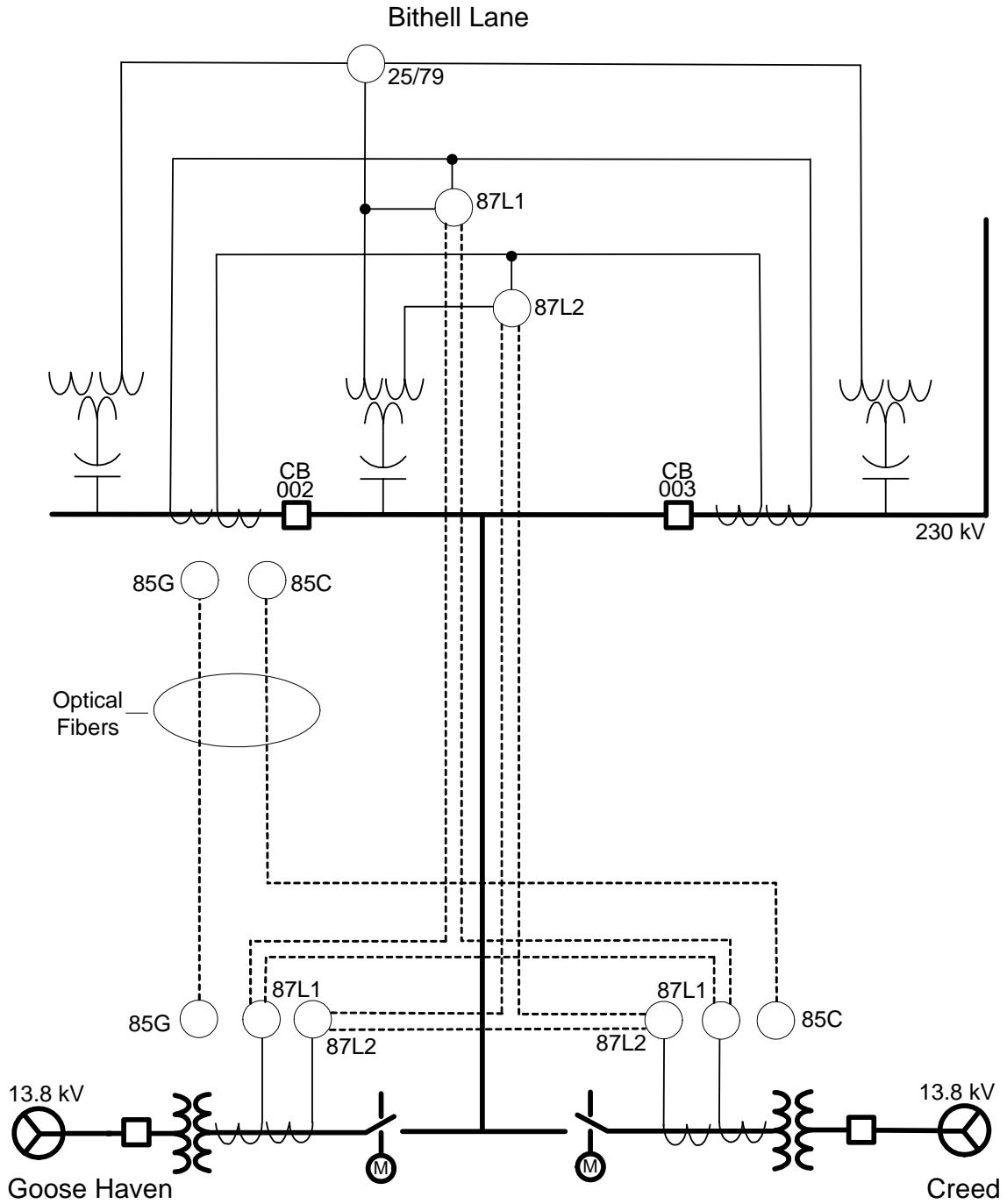

Figure 2. Protection and Restoration System Single Line Diagram

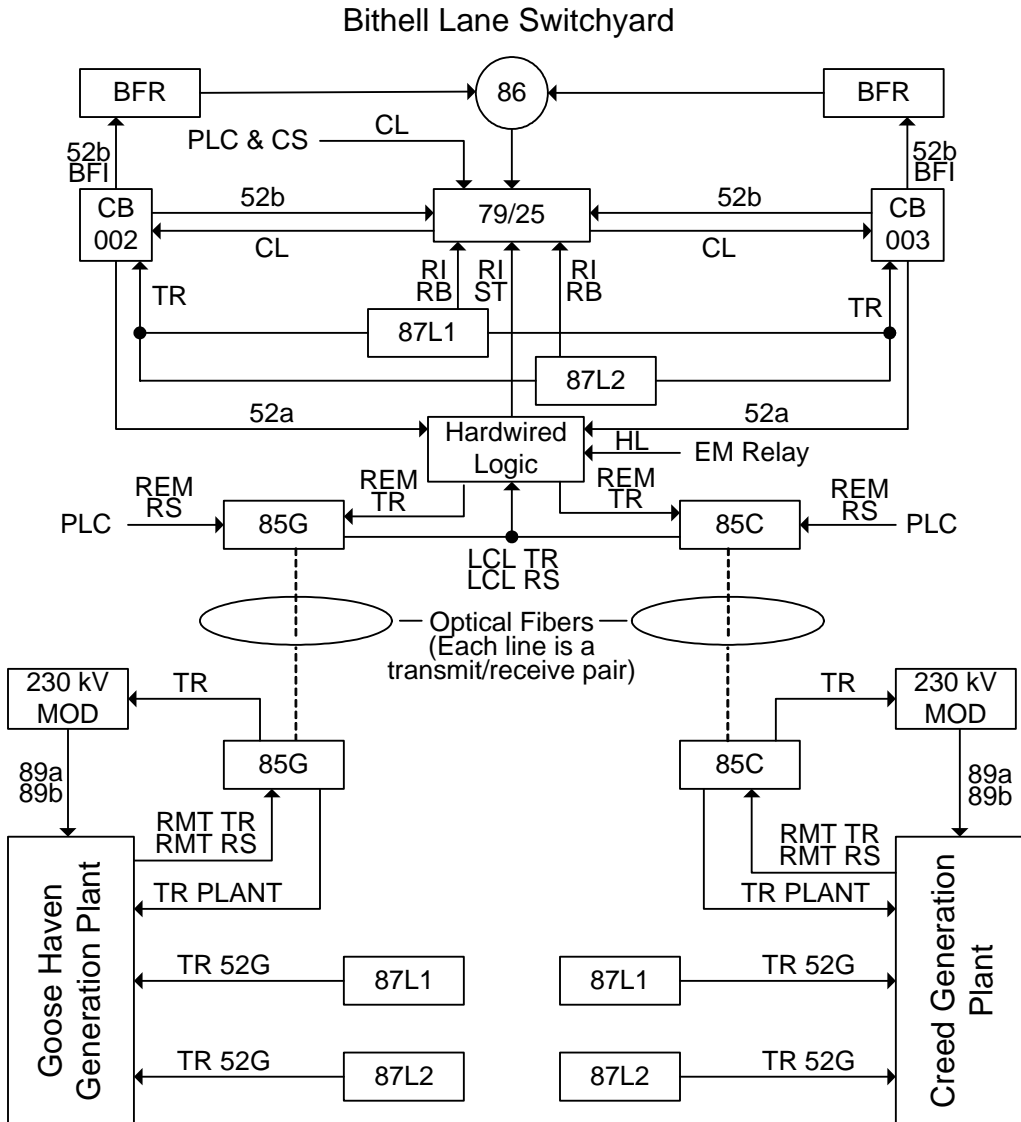

Figure 3. Protection and Restoration System Block Diagram

Abbreviations used in Figure 3:

BFI	Breaker Failure Initiate	RMT	Reset Remote 86 Lockout Relay
BFR	Breaker Failure Relay	RS	Reset Remote 86 Lockout Relay
CB	Circuit Breaker	RMT	Remote Trip 86 Lockout Relay
CL	Close	TR	TR
CS	Control Switch	TR	Trip or Open
DTL	Drive to Lockout	52a	Circuit Breaker Aux Switch (NO)
EM	Electromagnetic	52b	Circuit Breaker Aux Switch (NC)
HL	Hot Line Signal from EM Relay	52G	13.8kV Generator Circuit Breaker
LCL RS	Reset Local 86 Lockout Relay	79/25	Reclosing/Synch Check Relay
LCL TR	Reset Local 86 Lock Out Relay	85	Remote Input/Output Module
MOD	Motor Operated Disconnect	86	Electromechanical Lockout Relay
PLC	Plant PLC	87L1	Line Differential Relay Set 1
RB	Reclose Block	87L2	Line Differential Relay Set 2
RI	Reclose Initiate	89a	MOD Aux Switch (NO)
		89b	MOD Aux Switch (NC)

Because of the short line lengths and presence of generation, a relatively non-aggressive reclosing/auto-restoration scheme is implemented. One time delayed reclose is provided (after MOD and/or 13.8kV generator circuit breaker(s) open) for single phase and two phase line differential trips. A line reclose will not occur for three phase line faults, high magnitude faults on the line or within a GSU, time overcurrent trips, or for distance element trips. All of these conditions are indicative of a major fault, a failure of the primary line protection scheme, or a failure of the primary plant protection scheme. In any of these events operator intervention is required before reclosing the 230kV line.

The differential elements providing primary line protection do not require coordination with the electric utility and Lambie Energy Center protective relaying. The time delay for the backup distance elements is selected to be greater than the time for plant differential protection to operate and less than the Zone 2 step distance backup used by the electric utility. The instantaneous and inverse time overcurrent elements were set to coordinate with the electric utility backup relaying and the Lambie plant relaying through a combination of pickup values, directionality, and time current curve characteristics.

Normal Sequence of Events for a 230kV Line Fault

As an example the sequence of events following a single line to ground or phase to phase line fault follows:

- Fault occurs
- Trip signals and reclose initiate signals are provided by the two line differential relays at Bithell Lane (the relays directly trip both breakers).
- The two line differential relays at both plants directly trip the generator breakers initiating shut down of the plants.
- Both 230kV circuit breakers at Bithell Lane open, which trips plant lockout relays through the remote input/output modules. The plant lockout relays re-trip the generator circuit breakers and also trip auxiliary power circuit breakers.
- After a 20 second delay, the first 230kV circuit breaker at Bithell Lane closes, re-energizing the line (Note that a number of conditions can prevent reclosing, including breaker failure at either plant, breaker failure at Bithell Lane, dead bus condition at Bithell Lane, hot line condition, three phase fault, and operation of backup line protection elements).
- After a 30 second delay, the second 230kV circuit breaker at Bithell Lane closes.
- The system is left with the line and GSU transformers re-energized, 230kV circuit breakers closed, the generator circuit breakers open, and plant auxiliary power circuit breakers open. The plants are ready to be re-started.

Normal Sequence of Events for a Plant Fault

A second example is the normal sequence of events following a fault within the generation plant, for example, a fault within the GSU transformer.

- Fault occurs
- Fault is detected by the plant transformer differential relay, tripping a plant lockout relay and initiating trips within plant.
- The plant lockout relay, through the remote input/output modules, also trips a lockout relay at Bithell Lane, which initiates reclosing, stalls the reclosing relay timer, trips the two 230kV circuit breakers, and blocks closing of the 230kV circuit breakers.
- Both 230kV breakers at Bithell Lane open, which trips a second plant lockout relay at both plants through the remote input/output modules. The plant lockout relays re-trip the

generator circuit breakers and also trip auxiliary power circuit breakers. In addition, the motor operated disconnect (MOD) at the faulted plant is opened.

- When the MOD at the faulted plant is open, a “b” auxiliary switch closes, resetting the lockout relay at Bithell Lane. Resetting the lockout relay restarts the timer in the reclosing relay and removes the closing block on the 230kV circuit breakers.
- After a 20 second delay, the first 230kV circuit breaker at Bithell Lane closes, re-energizing the line. (Note that a number of conditions can prevent reclosing, including breaker failure at either plant, breaker failure at Bithell Lane, hot line condition, three phase fault, and operation of backup line protection elements).
- After a 30 second delay, the second 230kV circuit breaker at Bithell Lane closes.
- The system is left with the line and 230kV circuit breakers closed. At the non-faulted plant, the GSU transformer is re-energized, the generator circuit breaker and plant auxiliary power circuit breakers are open, and the plant is ready to be re-started. At the faulted plant, the MOD is open and the plant is de-energized.

Abnormal Situations

Failures of system components or of the system to operate as intended are considered in the design of the system. For example:

- A loss of communication that affects one of the communications legs between relays will not result in loss of protection. Both sets of line differential relays are designed to operate with no loss of functionality; however an alarm will be issued. If communication is lost between any two relays in a set, the relays will switch to a master-slave operating mode and continue to provide line differential protection. Refer to Figure 4.
- A loss of communications that affects two or three of the communications legs between either set of the line differential relays will result in an alarm. Protection will be provided by the time delayed distance and overcurrent elements and reclosing will not occur as a result. Refer to Figure 4.
- Failure of a line differential relay will result in an alarm, but scheme functionality will remain unaffected with the remaining set of line differential relays providing line differential tripping.
- Failure of a remote input/output module will result in an alarm. Failure of a remote input/output module to operate for a plant fault will disable the auto restore scheme and result in tripping on the backup distance and/or overcurrent elements. It will not result in loss of functionality for a line fault as the generator circuit breakers are directly tripped by both sets of line differential relays.
- Breaker failure at either of the plants or Bithell Lane will result in disabling of the auto-restoration scheme.
- Trips caused by high magnitude faults or the backup protection elements (phase and ground distance or overcurrent) indicate either a major fault or a failure of the protection system to operate normally and will result in disabling of the auto-restoration scheme.
- The 230kV line will not be re-energized from Bithell Lane unless the line is dead. The line reclosing is supervised by live bus/dead line logic in the reclosing relay.

behavior was properly understood it was a simple matter to correct the relay logic to make the scheme work properly.

Lesson No. 5 – If possible, stage and test the system on the bench prior to installation and commissioning. It was not possible on this project due to schedule constraints. Even though commissioning generally went well, extra time and an extra trip were spent troubleshooting the protection and restoration scheme (due in significant part to the item noted in Lesson No. 4).

Lesson No. 6 – If possible, install a communications processor and modem to allow remote access to the relays for managing relay settings and downloading event reports. Retrieval and review of event reports and relay metering data is almost inevitable during commissioning and often useful during the initial period of operation when the operating staff is learning to use and understand the protection system.

Conclusions

Today's generation of protective relays and fiber optic communications equipment make customized implementation of protection and restoration schemes, such as the one described in this paper, relatively simple, practical, and cost effective to implement. Maximizing the use of digital logic within numerical relays or other digital devices will result in systems that are more flexible, use fewer components, and will simplify design and wiring.